

XFP 10GER OC192IR

10Gbps XFP Optical Transceiver, 40km Reach

Features

- ◆ Supports 10GBE Application at the Data-Rate of 9.953Gbps to 10.3125Gbps
- ◆ Maximum link length of 40km with SMF
- ◆ 1550nm cooled EML laser and PIN photodiode
- ◆ XFP MSA package with duplex LC connector
- ◆ XFI High Speed Electrical Interface
- ◆ +5V, +3.3V power supply
- ◆ Power dissipation <3.5W
- ◆ 2-wire interface for management and diagnostic monitor
- ◆ Compatible with RoHS
- ◆ Compatible with IEEE 802.3ae 10 Gigabit Ethernet
- ◆ Compatible with Sonet OC-192/SDH STM-64

Applications

- ◆ SONET(OC-192)/SDH(STM64) line card
- ◆ 10GE Ethernet switches and routers
- ◆ 10GE Core-routers
- ◆ 10GE Storage
- ◆ Inter Rack Connection
- ◆ Other high speed data connections

Product Description

The XFP 10GER OC192IR transceiver comply with XFP MSA, and can support diverse applications for SDH/Sonet equipment including FEC (9.95Gb/s to 10.7Gb/s),as well as Ethernet LAN(10.325Gb/s) and WAN(9.95Gb/s) applications. The high performance cooled 1550nm cooled EML transmitter and high sensitivity PIN receiver provide superior performance for SONET /SDH and Ethernet applications at up to 40km links. Digital diagnostics functions are available via a 2-wire serial interface, as specified in the XFP MSA.

Absolute Maximum Ratings

Parameter	Symbol	Min	Max	Unit	Ref.
Storage Ambient Temperature Range		-40	+85	°C	
Powered case Temperature Range		-5	+70	°C	
Operating Relative Humidity	RH		80	%	
Supply Voltage Range @ 5V	Vcc5	-0.5	6.0	V	
Supply Voltage Range @ 3.3V	Vcc3	-0.5	4.0	V	

Any stress beyond the maximum ratings can result in permanent damage. The device specifications are guaranteed only under the recommended operating conditions.

Recommended Operating Conditions

Parameter	Symbol	Min	Typical	Max	Unit
Operating Case Temperature	Tc	0		+70	°C
Power Supply Voltage	Vcc5	4.75	5.0	5.25	V
	Vcc3	3.13	3.3	3.47	
Power Dissipation	PD			3.5	W

Transmitter E/O Characteristics

Parameter	Symbol	Min.	Typ.	Max.	Unit	Note
Operating Data Rate		9.95		11.1	Gb/s	
Ave. Output Power	Po	-1		2	dBm	1
Output Centre Wavelength	λ	1530	1550	1565	nm	
Disable Power	Poff			-30	dBm	
Extinction Ratio	ER	8.2			dB	1
Sidemode Suppression Ratio		30			dB	
Rise/Fall Time (20%~80%)	Tr/Tf			38	PS	
Dispersion penalty				2	dB	1
Generation Jitter1(20KHZ-80MHZ)				0.3	Ulp-p	1
Generation Jitter 2(4MHZ-80MHZ)				0.1	Ulp-p	1
Optical Eye Mask 1		GR-253-CORE/ITU-T G.691				1
Optical Eye Mask 2		IEEE802.3ae				2

Receiver E/O Characteristics

Parameter	Symbol	Min.	Typ.	Max.	Unit	Note
Operating Data Rate		9.95		11.1	Gb/s	
Overload	Po	0.5			dBm	
Input Centre Wavelength	λ	1270		1600	nm	
Minimum Sensitivity	Pmin			-12.3	dBm	1
Stressed Sensitivity in OMA				-10.3	dBm	2
LOS Assert	LosA	-30			nm	
LOS De-assert	LosD			-16	dBm	
LOS Hysteresis		0.5			dBm	

Optical Return Loss		27			dB	
Jitter Tolerance		GR-253-CORE/ITU-T G.783				1

Note :1. Measured at 9.95328Gb/s,Framed PRBS2^31-1,NRZ

2. Measured at 10.3125Gb/s,Non-framed PRBS2^31-1,NRZ

Pin Descriptions

Pin	Logic	Symbol	Name/Description	Note
1		GND	Module Ground	1
2		VEE5	Optional -5.2V Power Supply (Not required)	
3	LVTTL-I	MOD_DESEL	Module De-select; When held low allows the module to respond to 2-wire serial interface	
4	LVTTL-O	INTb	Interrupt; Indicates presence of an important condition which can be read via the 2-wire serial interface	2
5	LVTTL-I	TX_DIS	Transmitter Disable; Turns off transmitter laser output	
6		VCC5	+5V Power Supply	
7		GND	Module Ground	1
8		VCC3	+3.3V Power Supply	
9		VCC3	+3.3V Power Supply	
10	LVTTL-I/O	SCL	2-Wire Serial Interface Clock	2
11	LVTTL-I/O	SDA	2-Wire Serial Interface Data Line	2
12	LVTTL-O	MOD_Abs	Indicates Module is not present. Grounded in the Module	2
13	LVTTL-O	MOD_NR	Module Not Ready; Indicating Module Operational Fault	2
14	LVTTL-O	RX_LOS	Receiver Loss Of Signal Indicator	2
15		GND	Module Ground	1
16		GND	Module Ground	1
17	CML-O	RDN	Receiver Inverted Data Output	
18	CML-O	RDP	Receiver Non-Inverted Data Output	
19		GND	Module Ground	1
20		VCC2	+1.8V Power Supply (Not required).	3
21	LVTTL-I	P_DOWN/RST	Power down; When high, requires the module to limit power consumption to 1.5W or below. 2-Wire serial interface must be functional in the low power mode.	
			Reset; The falling edge initiates a complete reset of the module including the 2-wire serial interface, equivalent to a power cycle.	
22		V _{CC2}	+1.8V Power Supply (Not required)	3
23		GND	Module Ground	1
24	PECL-I	REFCLKP	Not used, internally terminated to 50ohm (100ohm diff).	4
25	PECL-I	REFCLKN	Not used, internally terminated to 50ohm (100ohm diff).	4
26		GND	Module Ground	1
27		GND	Module Ground	1
28	CML-I	TDN	Transmitter Inverted Data Input	
29	CML-I	TDP	Transmitter Non-Inverted Data Input	
30		GND	Module Ground	1

1. Module ground pins GND are isolated from the module case and chassis ground within the module.
2. Open collector; Shall be pulled up with 4.7K-10Kohms to a voltage between 3.15V and 3.6V on the host board.
3. The pins are open within module.
4. Reference Clock is not required.

Management Interface

The transceivers provide serial ID memory contents and diagnostic information about the present operating conditions by the 2-wire serial interface (SCL, SDA).

The Module provides diagnostic information about the present operating conditions. The transceiver generates this diagnostic data by digitization of internal analog signals. Alarm/warning threshold data is written during device manufacture. Received power monitoring, transmitted power monitoring, bias current monitoring, supply voltage monitoring and temperature monitoring all are implemented.

The digital diagnostic memory map specific data field defines as following.

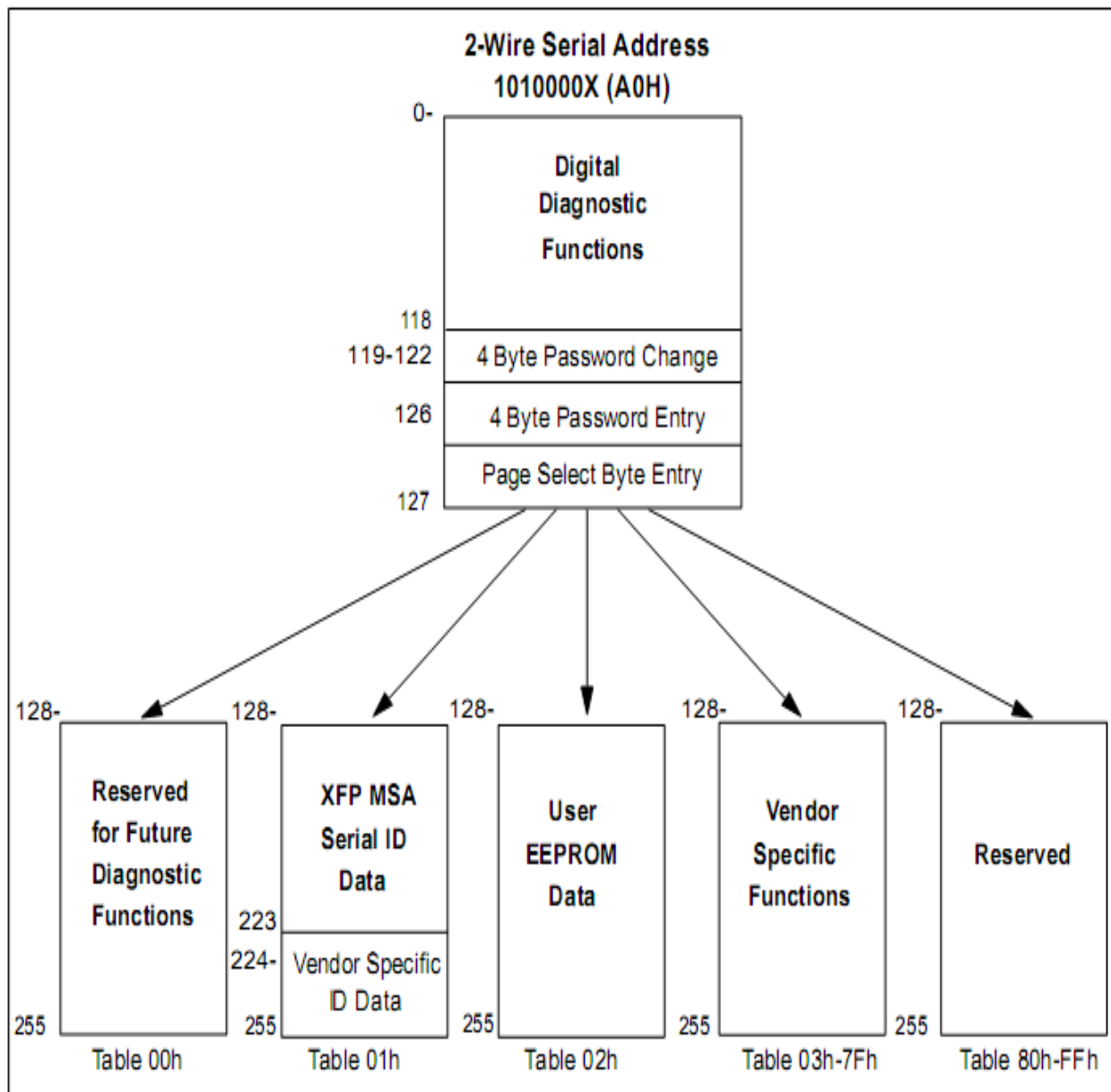

Recommended Host Board Power Supply Circuit

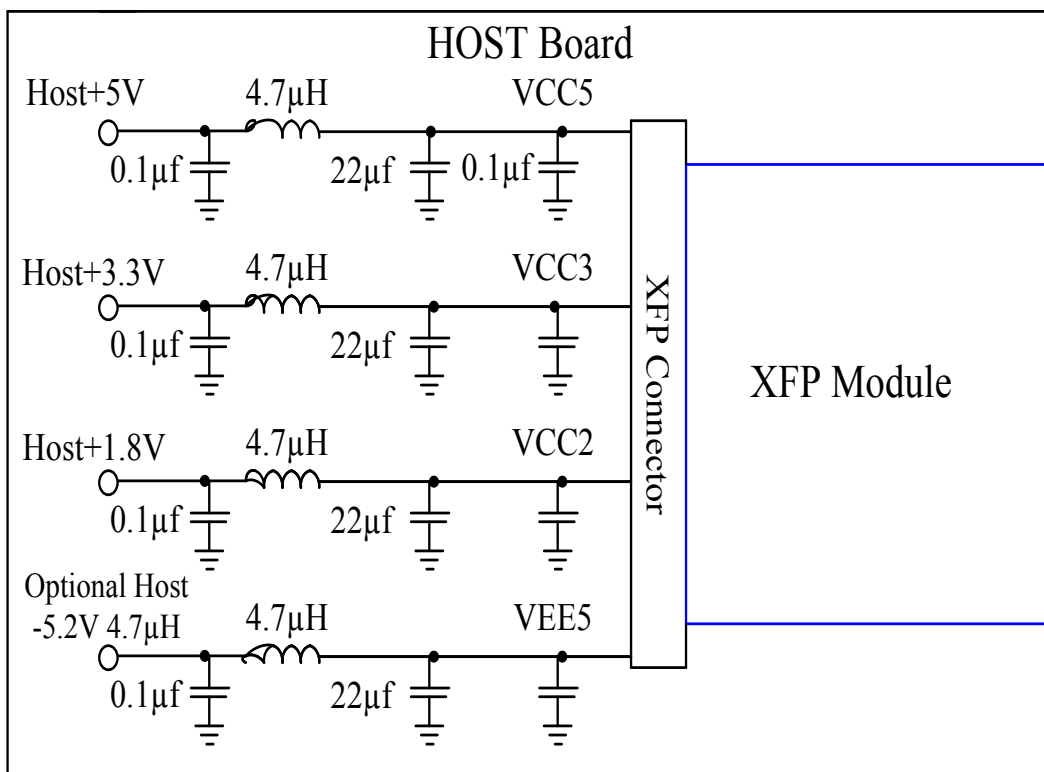

Recommended High-speed Interface Circuit

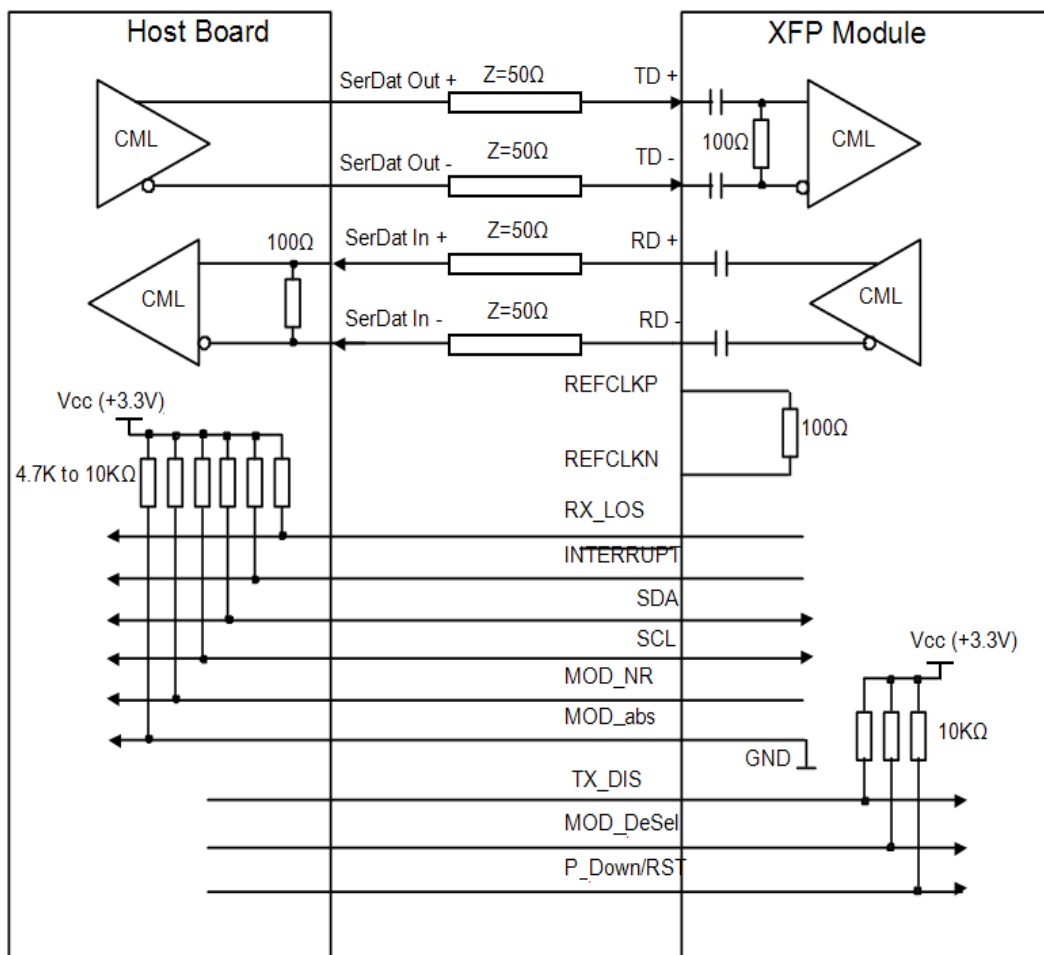

Package Dimensions

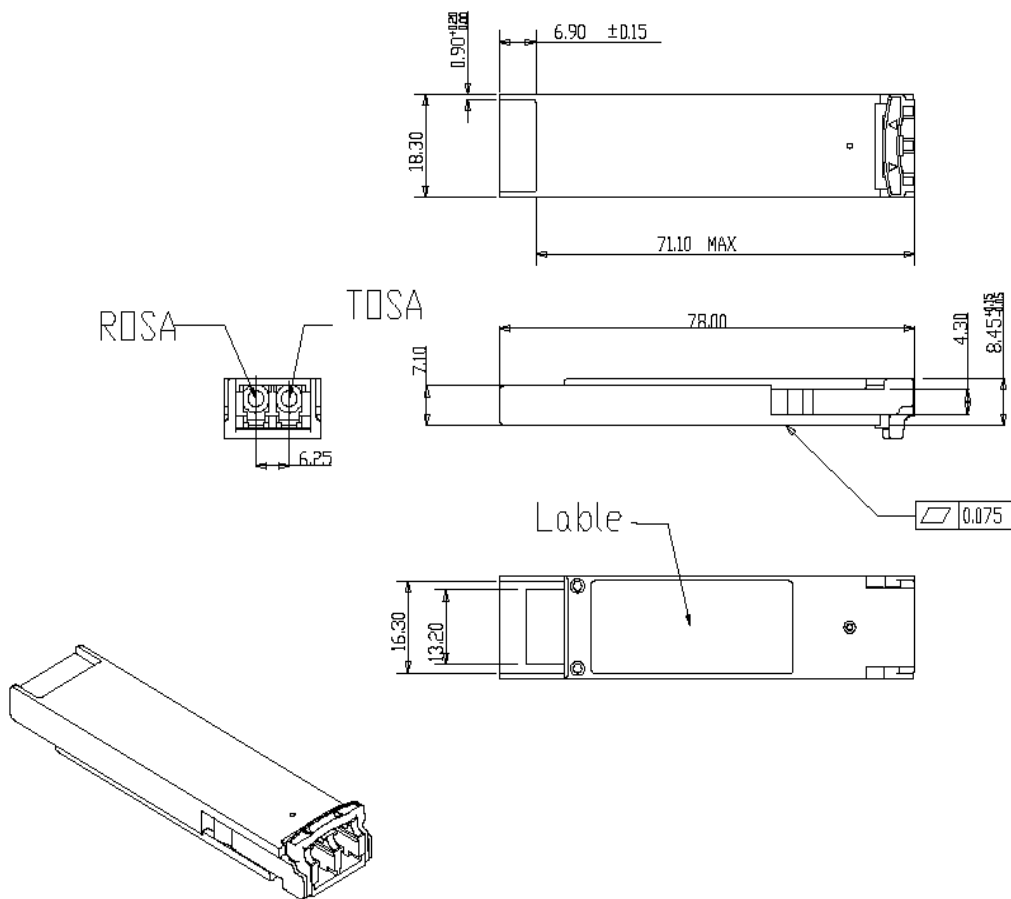

Ordering information

Part Number	Product Description
HXFP-10GER-OC192IR	1550nm cooled EML, 10Gbps, 40km, 0°C ~ +70°C